

DC Battery Charger

Model 9650 Series

Model 9650DC: Solar Photovoltaic Controller

Model 9650AC: AC-Powered Uninterruptible Power Supply

Applications

- Solar Photovoltaic Systems
- Uninterruptible Power Supply Systems
- Battery Charger
- Available in 12, 24, and 48 vdc Battery Systems
- For Charging NCad. Sealed and Wet Type Lead And Batteries.

Advanced Charging Features

- Automatic 3-Stage Charge Control, with
- Temperature Compensation
- Automatic Equalize Charge
- Voltage and Current Control
- Battery Monitoring
- Low Ripple Output

Greater Convenience and Cost Savings

- Digital Display of Current and Voltage
- Available in Connector or Terminal Interface
- Operates in Ambient Temperatures of -40° C to +60° C
- Weather-Resistant Enclosure
- Alarm conditions and charge cycle are displayed using LED's

Increased Safety

- Current Control in the Positive Circuit
- Over-Voltage and Over-Current
- Disconnect
- Reverse Polarity Protected
- Alarm Relay, Dry Contact; Form C
- Low Voltage Load Disconnect

Photovoltaic (PV) Charger. The Model 9650DC charger optimizes the voltage and current (power) produced by the PV Array, and regulates the charge into the battery. The PV Array has an optimum peak power (volts x current = power in watts) output where its' efficiency is greatest. With other charging systems, if the load draws too much current, the voltage drops



disproportionately and the power output drops. The Model 9650DC allows the PV Array to operate near its peak power point (i.e. 32 volts x 10 amps = 320 watts) and allows the battery and load to draw the maximum current (i.e. 25 volts x 12 amp = 304 watts). Note there is a 5% to 10% conversion loss (320-304 = 16 watts loss) and the battery is receiving 20% more current. As the battery reaches full charge, the power tracking becomes less significant because voltage is higher and current drops off.

The Series 9650 chargers incorporate a DC to DC switching circuit which converts the PV Arrays power output to the voltage and current levels required by the battery and the load.

UPS/DC, AC-Powered Uninterruptible Power Supply System for DC Loads. Model 9650AC uses an AC input and DC output to power the load. Typical UPS systems use an AC input and an AC output to power the load. Since most electronic load circuits require DC power, this technology provides for greater reliability, efficiency, and lower cost.

The Model 9650AC is similar to the 9650DC except there is a transformer, diode bridge, and capacitor circuit added, to step down the AC voltage and rectify it to DC. The transformer also provides line isolation.

DC Battery Charger

Operation During A Charge Cycle:

- A. Input power turns on; the charger applies a trickle current and waits until the battery voltage rises to point VT before applying full current. This is an important feature to prevent the battery from "boiling" and losing its electrolyte if
- B. The battery voltage reaches VT, turns off the trickle charge and now applies the full current (I max) output of the charger. This first stage of charging is referred to as the bulk charge. Bulk charging quickly restores the battery for another round of engine cranking.
- C. Transition voltage V12 is reached and the charger indicates that it is now in the second stage of charging; equalize. The charger is now charging at a constant potential (voltage).
- D. Battery voltage approaches the equalize level (VE) and the charge current begins to taper.
- E. Charge current tapers to IET. The charger senses the drop in current as the battery becomes fully charged, and changes to the third stage; float. The battery voltage is held at VF.
- F. Here, a load (greater than I max) begins to discharge the battery.
- G. The load discharges the battery, causing the voltage to fall below V31. The charger is now in the bulk rate again.

- Maximum current output (I max)
- Float voltage (VF) Equalize current termination
- (IOCT)-also referred as overcharge state.

Upon adjusting the above parameters, the following points are automatically set:

- Trickle charge termination (VT)
- Transition voltage (V12)

The automatic application of equalize and float charging ensures the battery is brought up to full charge with the minimum amount of water loss, or gassing. Temperature compensation is one of the most important features, providing optimum charging during changes in the environment. These charging features greatly improve the life and reliability of using NCad. sealed and maintenance free batteries.

National Electric Codes (NEC) requirements are met with the elimination of the diode or transistors in the negative circuit. Current sensing is in the positive circuit and galvanically isolated. A short in the negative circuit external to the charger will not affect the current control.

The output current is controlled and the voltage is regulated; however, should these circuits fail, a relay within the charger will open the circuit to the battery. The same relay is used to help prevent system damage if the battery is connected with reverse polarity.

The Series 9650 chargers are available with either a terminal strip or connector. Using a connector improves safety and reliability because there are no exposed terminals which can accidentally become shorted, and the connections are shielded against the environment.

Enclosure:

Corrosion resistant, hard anodized aluminum cover and chassis, equipped for rack, table, or wall mounting. The enclosure is sealed and weather resistant. The control panel consists of digital volt and amp meters, input power, on/off circuit breaker, battery on/off circuit breaker, and operational LED monitors.

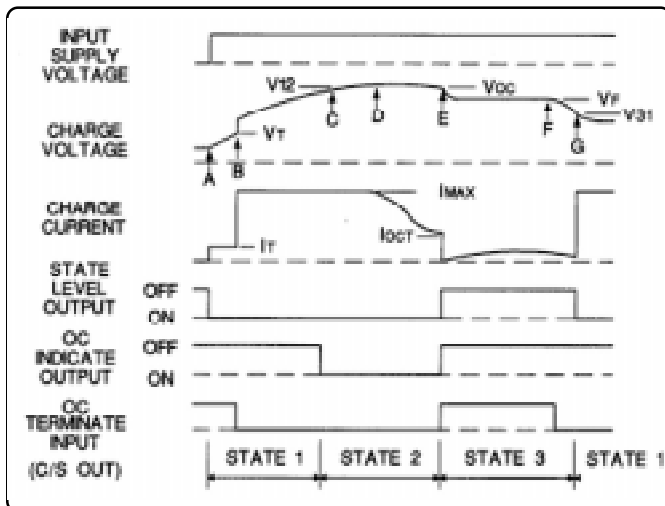

The Series 9650 chargers allows the technician in the field to adjust the set points for different battery types (NCad. and lead acid) and amp hour capacities. The following parameters are adjustable:

Series 9650 Alarms and Protection Features:

Over-voltage. Should output voltage rise above a factory preset level, the controller will disconnect the battery from the controller via an internal relay. A visual LED alarm is provided in the front panel. Alarm Relay is triggered. This circuit failure will require manual reset, by switching off input power.

Over-current. Should the output current raise above a factory preset level, the controller will disconnect the battery from the controller via an internal relay. A visual LED alarm is provided in the front panel. Alarm Relay is triggered. This circuit failure will require manual reset, by switching off input power.

No Load. The charger monitors the output current to make sure that there is a battery and load connected. This set point is field connected. A visual LED alarm is provided and the Alarm Relay is triggered. Alarm condition is automatically reset when the circuit senses the load. False alarms can occur when there is a small load and the charger switches from equalize to float. When charging at equalize (overcharge) battery is brought to a high potential; switching to float, which is at a lower potential, creates a short term condition where the battery potential is higher than the charger output. No current can flow from the charger creating the alarm condition. As the battery voltage decays to the float voltage the alarm goes away.

Low-Voltage Load Disconnect. This feature disconnects the load to protect the battery from being over-discharged. The disconnect point is field adjustable. The load reconnects automatically after the battery voltage climbs 3-4 volts above the disconnect setting.

Remote temperature sensor. This sensor monitors the battery temperature and adjusts the float voltage for optimum charging. The sensor incorporates a thermister. Any changes to the cable length or the incorporation of terminals or connectors will require recalibration of the float voltage.

The Models 9650DC and 9650AC are fully automatic chargers. No operator intervention is required once calibrated and installed. Other than calibration every two years, there is no maintenance.

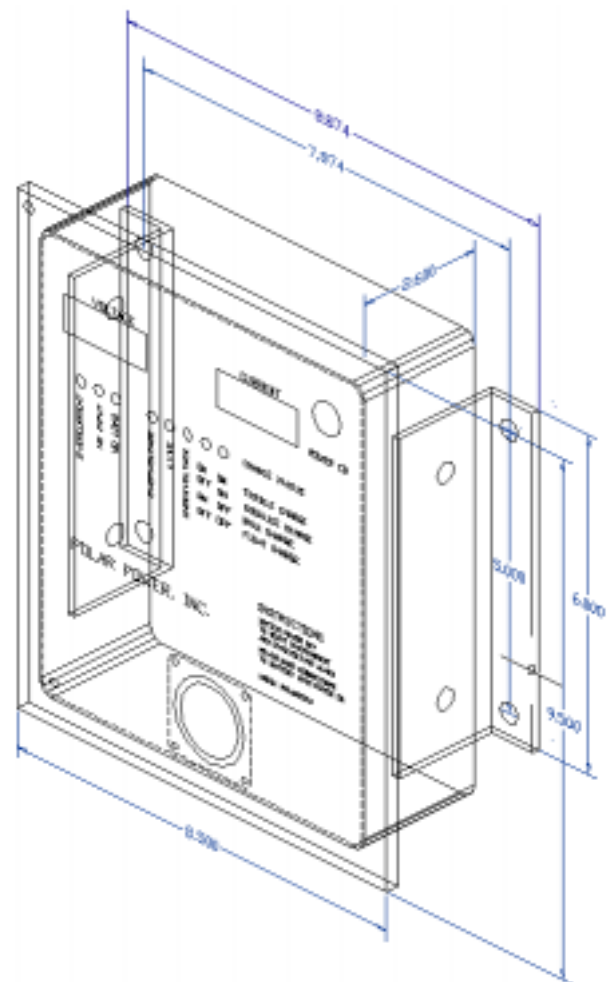

Due to the reverse polarity circuit and relay, it is important to:

1. connect the battery
2. close the battery circuit breaker/switch
3. close the input (power) circuit breaker.